

CHAIR VERTE ASSEMBLY

1 STEP ONE

Determine the Verte Model.

2 STEP TWO

Set the seat assembly upside down on the corner of a table. Locate the (3) Hex Head Bolts.

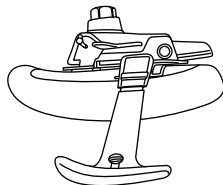
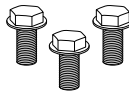

3 STEP THREE

For Models 22011, 22111, and 22517:

You will need a 9/16" wrench. Move the seat slider/control back as far as possible. Position back bar of the Verte back into the control back bracket. Be sure to slide the back bar onto the bracket with threaded nuts in place on the underside of the control back bracket.

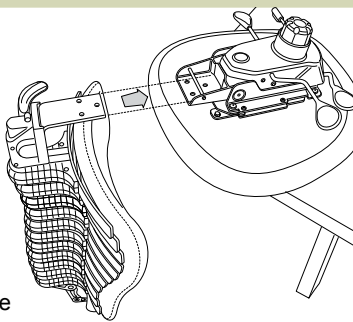

For Model 22305:

You will need a 1/2" wrench. Slide cushion back bar into control bar bracket. Align holes and hand screw the 3 black bolts into the bar. Tighten the 3 bolts to secure the back.

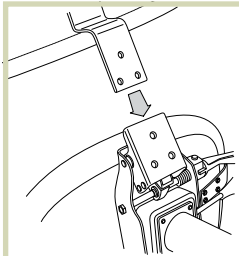

4 STEP FOUR

Slide cushion back bar into control bar bracket. Align holes and hand screw the 3 black bolts into the bar. Tighten the 3 bolts to secure the back.

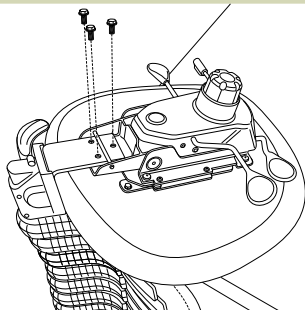

5 STEP FIVE

Place base w/casters on the floor; push the cylinder into hole in center of base with the tapered end down. Place plastic can cover on top of cylinder with the larger side down.

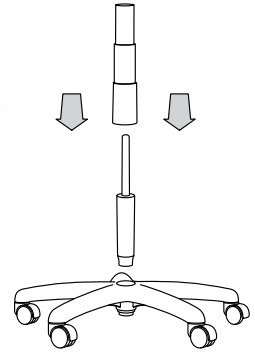

6 STEP SIX

Insert cylinder into hole on seat control. Once cylinder is inserted into the control, turn the chair over carefully, and sit on the seat to secure it together.

Please note that the Verte back weighs 45 lbs.

Your Verte is now assembled. Enjoy! Thank you for choosing RFM!

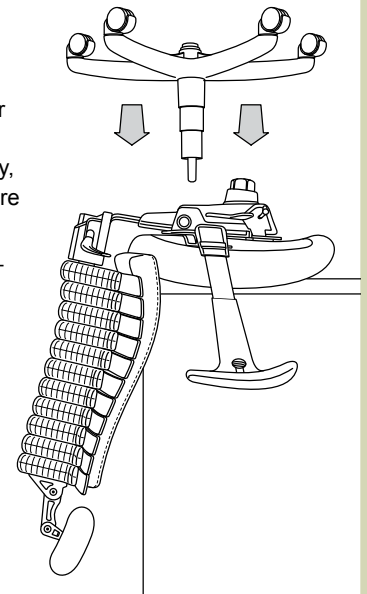

To learn how to adjust your new RFM chair, please visit our website at www.rfmseating.com. Go to the Customer Service drop down and then scroll to How to Adjust. If you still have questions, please call customer service at 800 447-5542.